

SYSTEMA

HEATING COOLING GREEN ENERGY

SCR-ELE

Electric radiant emitters, Heating of various types of environments from 1500 to 6000 W

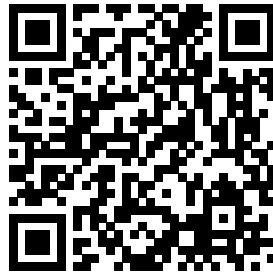

**FAST AND EASY
INSTALLATION**



**IS AN ECOLOGICAL
SOLUTION**



**SILENT AND
HEALTHY**

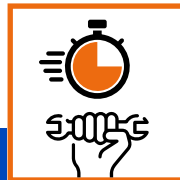

**LOW
MAINTENANCE**

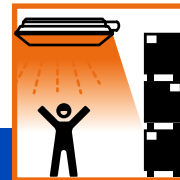

**FAST AND HIGH
THERMAL COMFORT**



**LOW RUNNING
COSTS**

GENERAL FEATURES

SCR-ELE emitters are a radiant heating system that is flexible in its application and use, depending on the model using either special medium-fast wave lamps (providing more diffuse heat to the subservient environment) or short wave lamps (more concentrated, faster heat).

SCR-ELE thanks to the absence of combustion and reduced emissions (R.O.A. D. Lgs. 81/08, directive 2006/25/CE) **are heating systems that respect the environment and are in line with the ecological transition directive.**

They are designed to heat any type of environment, their operation is completely autonomous and they do not require any special masonry work for installation, making it possible to satisfy the most varied needs in heating environments, they can in fact be installed even in places that are difficult to reach, niches, as well as in large areas, their lightness is one of their strong points, in fact their weight reaches a maximum of only 7.5 kg.

Their ease of installation and flexibility allow for zone heating by concentrating heat only in specific selected areas, only where it is needed, as much and when it is needed; eliminating the unnecessary cost of heating large areas entirely.

The entire **SCR-ELE** range consists of various models with wattages ranging from 1500 to 6000 W. They can be installed on sloping walls, ceilings, or in combination with the movable telescopic pole (optional), which allows the emitter to be positioned where it is needed, and switched on with a simple switch, to have **the required heat and well-being within just 60 seconds of switching on.**



ADVANTAGES

- Greater thermal comfort with lower air temperature
- No thermal gradient and therefore less dispersion
- No air movement and no dust in suspension
- Immediate start-up
- Possibility of zone heating
- Absolute silence
- Energy saving and respect for the environment:
 - Reduced system running time due to low thermal inertia. Rapid start-up, even after prolonged shutdowns, and very low maintenance costs complete the system's economy of operation.
 - Produced with a totally Italian thread

FIELDS OF APPLICATION

- Churches,
- Gyms,
- Industrial sheds,
- Mechanical workshops,
- Craft workshops,
- Tensile structures,
- Sports halls,
- Recreational premises,
- Depots,
- Showrooms,
- Passage areas for railway stations,
- Shopping centres,
- Airports,
- Schools,
- Toy libraries,
- Playgrounds (indoors),
- Bars,
- Restaurants,
- Dehors,
- Theatres.
- Professional use of greenhouses,
- Poultry farms,
- Heating animals (kennels),
- Workstation heating,
- Shooting ranges,
- Paddocks/racing pits,
- Sports areas,
- Rental,
- Food heating.

CONSTRUCTION FEATURES

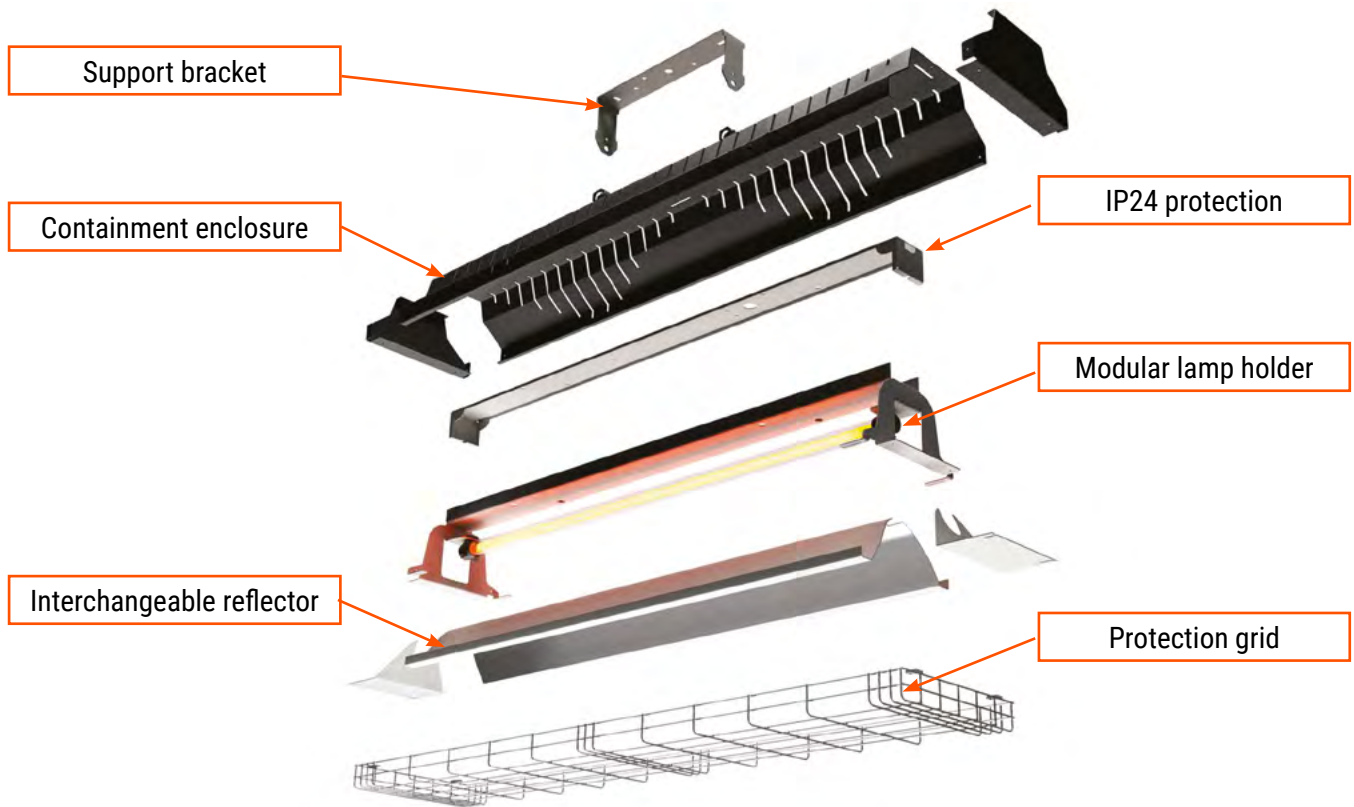

Packet-shaped protection grid to protect the emitter from accidental external shocks, designed to also obtain the greatest dissipation flux of the emitter facing the ground.

IP24 protection designed to protect the electrical wiring.

External containment casing in expanded metal and heavy galvanised sheet 15/10 thick and epoxy powder coated.

Interchangeable reflector, our emitters can be fitted with two types of reflectors that allow two different angles, allowing you to choose the best solution for heat concentration and thermal effect on the bodies.

Adjustable support bracket equipped with a stop to allow tilting and directing of the heat flow generated by the emitter.

Modular lamp holder made of hot-dip galvanised expanded steel, which allows it to absorb all the variations that may be generated by thermal expansion due to the heating of materials while maintaining the structure of the emitter intact.



SCR-ELE MV

Infrared heat emitter equipped with a special fast medium wave lamp consisting of:

- Interchangeable highly reflective aluminium reflector.
- Special translucent quartz lamp with fast medium wave emission, Teflon cable and silicone glass fibre coating.
- Optimised symmetrical diffusion.
- Standard optic with diffusing focal spot or possible optic with concentrating focal spot (on request).
- Complete with electrical cable, length 3 m and plug.
- Scratch-proof epoxy powder coating and suitable for outdoor use embossed/smooth.
- AISI 316 stainless steel versions also available on request
- Reduced R.O.A. emission (D.Lgs.81/08, directive 2006/25/CE)
- Approved for installation at 90° to the vertical (facing the floor)
- Standard colour RAL 9003 other colours available on request.

SCR-ELE MV-1650
SCR-ELE MV-2250



SCR-ELE MV-2500XL
SCR-ELE MV-4000
SCR-ELE MV-5250



| Model | Power |
|-------------------|--------|
| SCR-ELE MV-1650 | 1650 W |
| SCR-ELE MV-2250 | 2250 W |
| SCR-ELE MV-2500XL | 2500 W |
| SCR-ELE MV-4000 | 4000 W |
| SCR-ELE MV-5250 | 5250 W |

| Model SCR-ELE MV | | MV 1650 | MV 2250 | MV 2500XL | MV 4000 | MV 5250 |
|------------------------------------|-----|-----------------|---------|-----------|------------------|---------|
| Supply voltage | | 230Vac - 50Hz | | | 400Vac - 50Hz | |
| Dimensions WxHxD including bracket | mm | 830 x 214 x 180 | | | 1245 x 214 x 180 | |
| Max. weight | kg | 5 | 5 | 7,5 | 7,5 | 7,5 |
| Estimated average bulb life time | ore | 6500 | 6000 | 8000 | 4500 | 4000 |
| Temp. Max. rear 45° inclination | °C | <60 | <60 | <60 | <60 | <60 |
| Temp. Max. rear towards floor | °C | <70 | <70 | <80 | <80 | <80 |

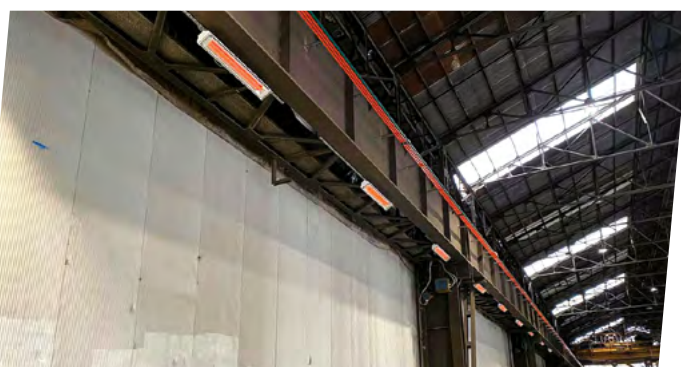
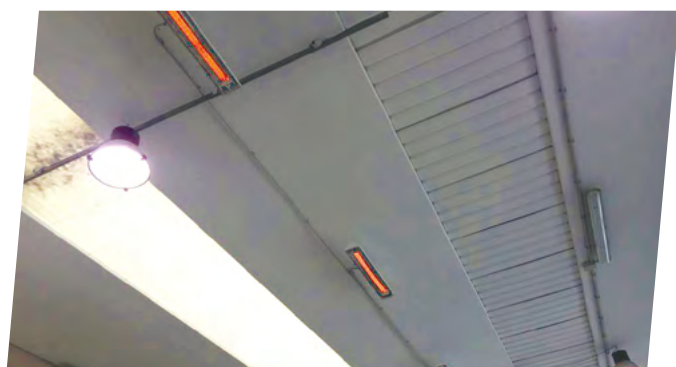

SCR-ELE G

Infrared heat emitter equipped with a special short-wave lamp consisting of:

- Interchangeable highly reflective aluminium reflector.
- IR halogen lamp with short wave emission, Teflon cable and silicone glass fibre coating.
- Optimised symmetrical diffusion.
- Standard optic with diffusing focal spot or possible optic with concentrating focal spot (on request).
- Supplied complete with electrical cable, 3 m long and Schuko plug (mod. G ONLY)
- Scratch-proof epoxy powder coating suitable for outdoor use embossed/glossy.
- Reduced R.O.A. emission (D.Lgs.81/08, directive 2006/25/CE)
- Approved for installation at 90° to the vertical (facing the floor)
- Standard colour RAL 9003 other colours available on request.

SCR-ELE G 1500
SCR-ELE G 2000



SCR-ELE G 3000
SCR-ELE G 4000

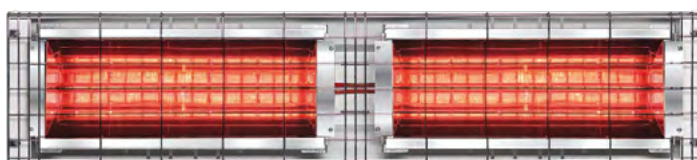

SCR-ELE G 4500
SCR-ELE G 6000



| Model | Power |
|----------------|--------|
| SCR-ELE G 1500 | 1500 W |
| SCR-ELE G 2000 | 2000 W |
| SCR-ELE G 3000 | 3000 W |
| SCR-ELE G 4000 | 4000 W |
| SCR-ELE G 4500 | 4500 W |
| SCR-ELE G 6000 | 6000 W |

| Model SCR-ELE G | | G 1500 | G 2000 | G 3000 | G 4000 | G 4500 | G 6000 |
|------------------------------------|-----|-----------------|--------|-------------------------------|--------|------------------|--------|
| Supply voltage | | 230Vac - 50Hz | | 230Vac - 50Hz / 400Vac - 50Hz | | | |
| Dimensions WxHxD including bracket | mm | 420 x 116 x 180 | | 830 x 116 x 180 | | 1245 x 116 x 180 | |
| Max. weight | kg | 5 | 5 | 7,5 | 7,5 | 7,85 | 7,85 |
| Estimated average bulb life time | ore | 5000 | 5000 | 5000 | 5000 | 5000 | 5000 |
| Temp. Max. rear 45° inclination | °C | <30 | <33 | <39 | <40 | <46 | <58 |
| Temp. Max. rear towards floor | °C | <54 | <54 | <54 | <55 | <60 | <63 |

SCR-ELE B

Infrared heat emitter equipped with a special short-wave lamp consisting of:

- Interchangeable highly reflective aluminium reflector.
- IR halogen lamp with short wave emission, Teflon cable and silicone glass fibre coating.
- Optimised symmetrical diffusion.
- Standard optic with diffusing focal spot or possible optic with concentrating focal spot (on request).
- Complete with electrical cable, length 1.9 m and plug.
- Scratch-resistant epoxy powder coating and suitable for outdoor use embossed/smooth.
- AISI 316 stainless steel versions also available on request
- Reduced R.O.A. emission (D.Lgs.81/08, directive 2006/25/CE)
- Approved for installation at 90° to the vertical (facing the floor)
- Standard colour RAL 9003 other colours available on request.

SCR-ELE B 1500 SCR-ELE B 2000

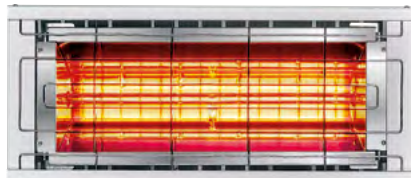

| Model | Power |
|----------------|--------|
| SCR-ELE B 1500 | 1500 W |
| SCR-ELE B 2000 | 2000 W |

| Model SCR-ELE B | | B 1500 | B 2000 |
|------------------------------------|-----|-----------------|--------|
| Supply voltage | | 230Vac - 50Hz | |
| Dimensions WxHxD including bracket | mm | 420 x 214 x 180 | |
| Max. weight | kg | 2,5 | 2,5 |
| Estimated average bulb life time | ore | 5000 | 5000 |
| Temp. Max. rear 45° inclination | °C | <60 | <60 |
| Temp. Max. rear towards floor | °C | <70 | <70 |

SCR-ELE Basic

Infrared heat emitter equipped with a special short-wave lamp consisting of:

- Interchangeable highly reflective aluminium reflector.
- IR halogen lamp with short wave emission, Teflon cable and silicone glass fibre coating.
- Optimised symmetrical diffusion.
- Standard optic with diffusing focal spot or possible optic with concentrating focal spot (on request).
- Supplied complete with electrical cable, length 3 m
- Heavy-weight scratch-resistant epoxy powder coating suitable for outdoor use embossed.
- Reduced R.O.A. emission (D.Lgs.81/08, directive 2006/25/CE)
- Equipped with inclined bracket for direct fastening on floor stand
- Standard colour RAL 9003 other colours available on request.

SCR-ELE Basic 1500 SCR-ELE Basic 2000

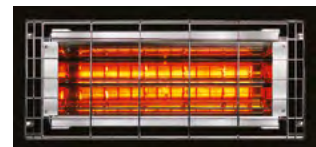
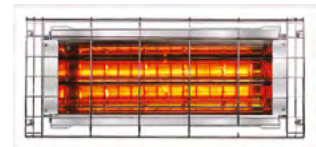

| Model | Power |
|----------------|--------|
| SCR-ELE B 1500 | 1500 W |
| SCR-ELE B 2000 | 2000 W |

| Model SCR-ELE Basic | | Basic 1500 | Basic 2000 |
|------------------------------------|-----|-----------------|------------|
| Supply voltage | | 230Vac - 50Hz | |
| Dimensions WxHxD including bracket | mm | 430 x 214 x 180 | |
| Max. weight | kg | 2,5 | 2,5 |
| Estimated average bulb life time | ore | 5000 | 5000 |
| Temp. Max. rear 45° inclination | °C | <60 | <60 |
| Temp. Max. rear towards floor | °C | <70 | <70 |

TELESCOPIC INDUSTRIAL STAND

The portable industrial telescopic pole stand is specially designed for all those situations where it is not necessary to heat the entire hall but only certain work areas.

This solution allows the **SCR-ELE** to be portable, guaranteeing energy savings and efficiency.

The base of the stand is modular in two solutions, one with a narrow base and one with a wide base, adapting to the customer's most convenient requirements.

Max. height 2855mm

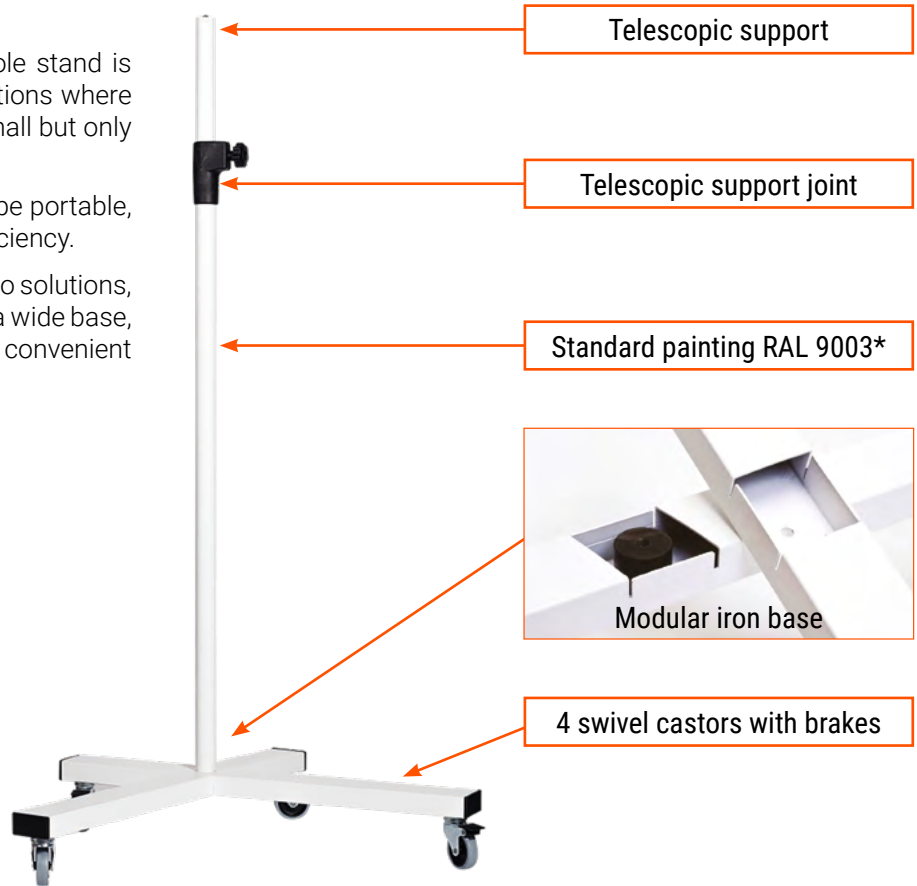

AUTOMATIC MOVER

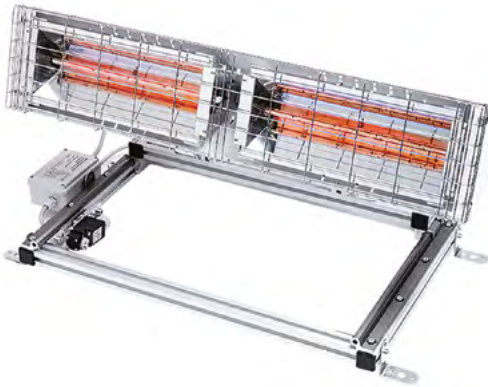

The automatic mover is suitable for all SCR-ELE models, and its aluminium construction makes it robust and light-weight.

It consists of side brackets for optimal attachment to all surfaces, the linear sliding supports are equipped with self-cleaning and self-lubricating dry runners.

It is driven by a chain-driven motor, and the limit switch allows precise adjustment and automatic switching on or off of the emitter.

The mounting height of the emitter is adjustable and has a self-protection in case of overheating.

Manufactured and customised according to the depth of the cornice and the size of the emitter.

POWER REGULATORS

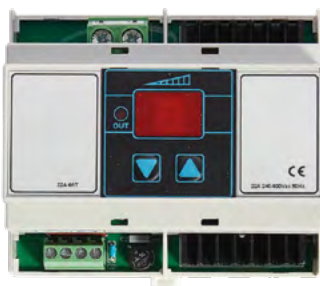

SYS CONTROL 22A

The **SYS CONTROL 22A** digital controller allows the power of **SCR-ELE** to be set from 0 to 100 per cent in 20 adjustment levels with a 5 per cent increment per level with a simple push of the buttons ▲ and ▼.

SYS CONTROL power controllers are programmable with synchronised zero-crossing multi-load control, or single three-phase load. They are suitable for controlling infrared lamps with high initial power consumption and are designed with modular DIN-rail technology for installation inside switchboards. This control allows greater lamp longevity thanks to the built-in soft-start, which allows perfect power regulation, variability of phase response times, and zero-crossing start-up and shutdown at all times.

Static relay 22A, suitable for controlling single-phase 240 and 400 Vac loads.



Since 1986, Systema S.p.A. is one of the leader companies in Italy and Europe in designing, developing and producing devices for the heating and conditioning in industrial and commercial buildings.

There has been always in Systema's Research and Development department where high investments have been made, since the beginning, for the creation of an internal laboratory who could design and offer highly innovative products that can satisfy and anticipate all the requests coming from the market. In this field Systema works together with important Italian, European and extra-European laboratories and university departments. A cooperation which leads to the concept of innovative and visionary products and solutions and to the obtaining of several international patents.

Systema S.p.A. differs from competitors because can offer a complete range of products that goes from commercial and industrial heating with radiant and hot air solutions, to conditioning with absorption chillers, electric heat pumps and evaporative adiabatic coolers and with a specific focus on the agricultural and breeding farms products for heating (both heaters and radiant systems) and conditioning with adiabatic coolers. This range has been conceived looking for environmental-friendly products with the lowest energy consumption.

Managing such a large range of products is not easy but, also in this field, Systema S.p.A. has been always different with an internal and external organization that guarantees high quality services through an extensive commercial network made of highly qualified technical salesmen, an internal organization of customer service with experience in designing and consultancies well aware of all the required standards and rules and a massive after sales structure both internal and external that Systema keeps regularly update in order to have technicians who are always very well prepared.

The work of these structures is greatly facilitated by Systema S.p.A.'s production facilities, which are made up of the highest quality standards and production processes that are technologically advanced and constantly modernised. The united work of those responsible for production, procurement and quality allows Systema S.p.A. to make available to its commercial structure products and systems that are of high quality, reliable and made in full compliance with the most advanced standards.

Systema S.p.A. is able to supply its sales organisation with products and systems of high quality and reliability and manufactured in full compliance with the most advanced standards.

Systema S.p.A. has thus managed, over the years, to gain a strong international presence which sees it active in markets all over the world, carrying forward the flag of top quality Made in Italy and achieving leadership positions in many countries. A strategic decision was taken by Systema S.p.A. to create Systema Polska, which is able to provide a highly qualified, high quality production force and a commercial structure, in synergy with that of Systema S.p.A., which is able to present and improve the commercial penetration of Systema products in markets such as Poland and neighbouring countries.

The synergies put in place have greatly facilitated the growth of the services offered to the market, services made up of a very high level of attention to the customer, who in Systema finds not only a business partner but also a highly qualified technical consultancy service that goes hand in hand with reliable after-sales services that are always ready to quickly resolve any problems reported by the customers themselves.

*Systema: focus on the future
by interpreting the present...*



SYSTEMA S.p.A. Via San Martino, 17/23 - Santa Giustina in Colle C.A.P. 35010 PADOVA - ITALIA

Tel. +39.049.9355663 r.a. - export@systema.it

www.systema.it